

WHAT WILL YOU NEED?

You will need the following to assemble your direct drive turbine.

Alternator (Stator & Rotor)

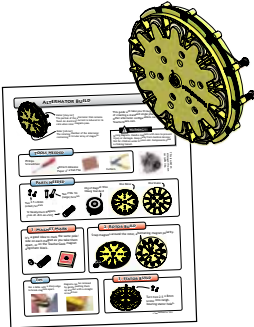

A guide for creating the alternator is available at TeacherGeek.com or by clicking [here](#).

Blades & Hub

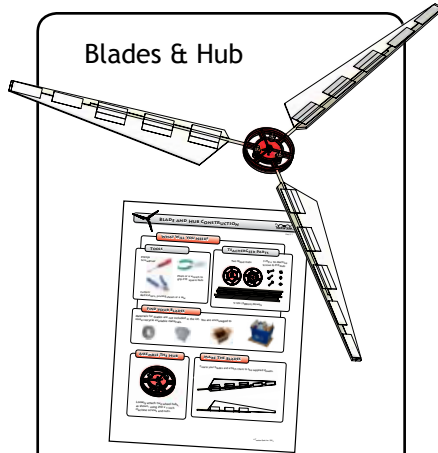

A guide for creating the blades & hub is available at TeacherGeek.com or by clicking [here](#).

One 7in (180mm) Dowel



One #10 Washer

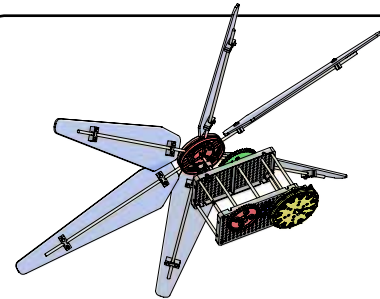

A gearbox can be added to your direct drive turbine to increase power output.

1. ATTACH THE AXLE

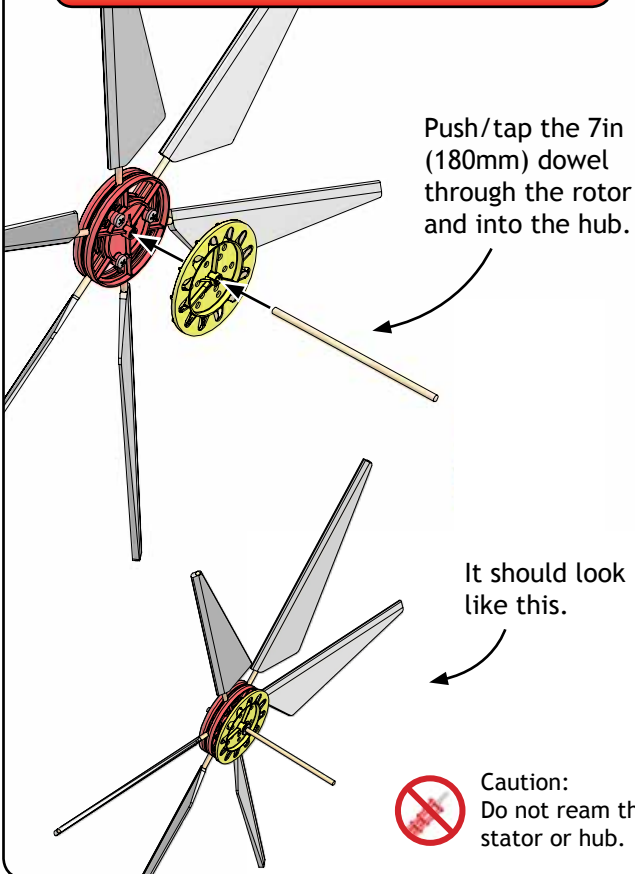

Push/tap the 7in (180mm) dowel through the rotor and into the hub.

It should look like this.



Caution: Do not ream the stator or hub.

2. SLIDE ON THE STATOR

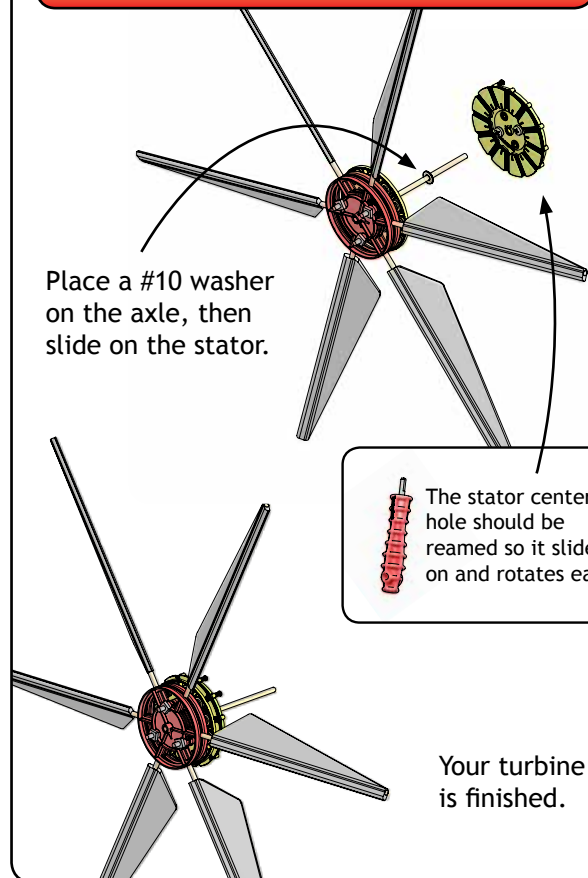

Place a #10 washer on the axle, then slide on the stator.



The stator center hole should be reamed so it slides on and rotates easily.

Your turbine is finished.

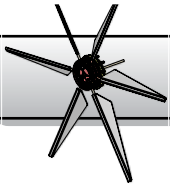

3. STAND IT UP

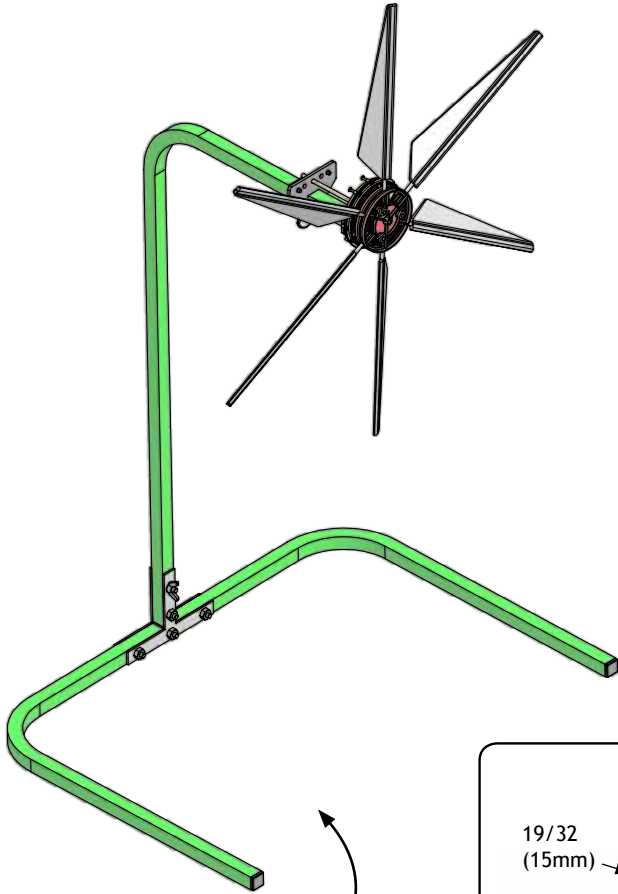

Use the TeacherGeek stand or create your own.

